

# DATASHEET

Frame Set 1x/ 2x/ 3x for Keystone Modules

Art.-No.: ET-251xx



front view ET-25108 assembled  
(without labeling field)

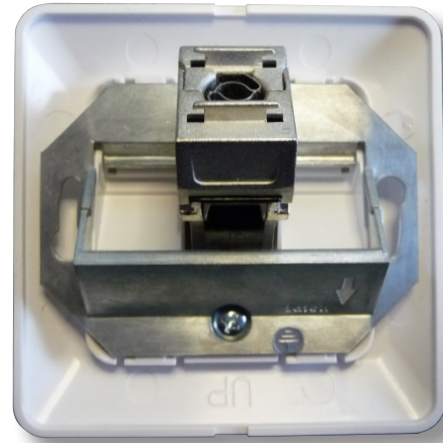

rear view ET-25108 assembled



ET-25108



ET-25109



ET-25110

## Features

- Takes 1, 2 or 3 RJ45 keystone modules (e.g. E-20070 or E-20072)
- Housing material: zinc diecast
- Special designed central plate + cover plates for carrying up to 3 keystone modules
- Colour RAL9010, pure-white
- Hinged dust covers and labeling field cover
- Special cover plates 80 x 80 mm (for snap-on from frontside after installation) included in delivery
- Delivery without modules



Art.-No.	ET-251xx	File	ET-251xx_NEU.indd		
Description	Frame Set for Keystone Modules				
Created	Date	Last Revision	Date	Checked	Date
Alexander Müller	23.09.2013	BT	11.02.2014	BT	11.02.2014

# DATASHEET

## Frame Set 1x/ 2x/ 3x for Keystone Modules

Art.-No.: ET-251xx

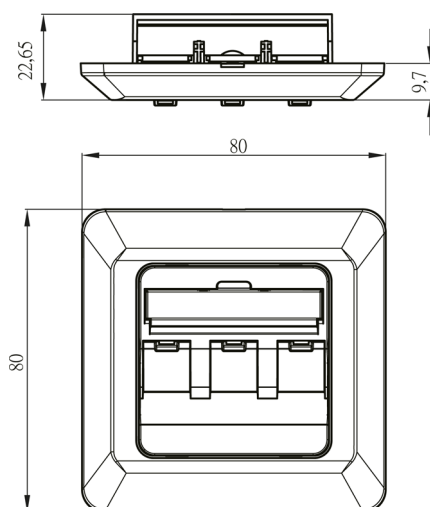
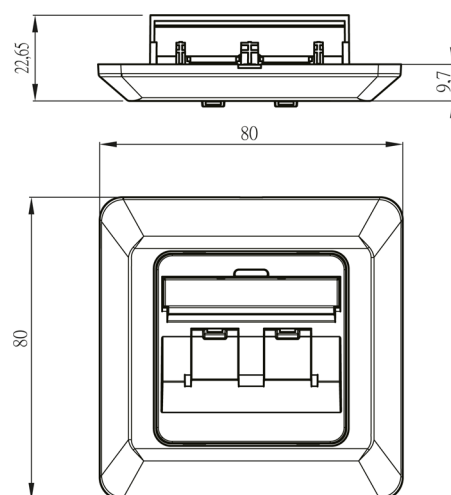
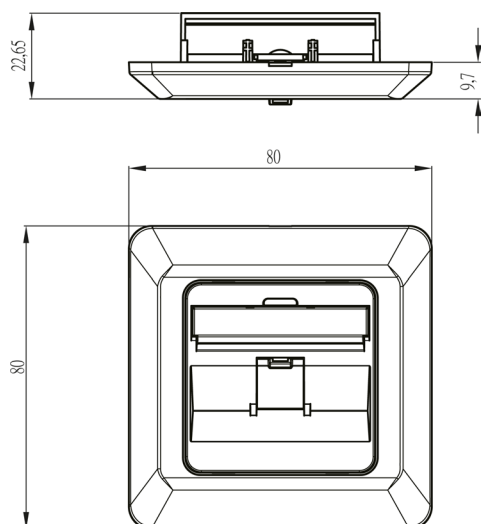

### Order data

Art.-No.	Type
ET-25108	1-port, RAL9010 (pure-white)
ET-25109	2-port, RAL9010 (pure-white)
ET-25110	3-port, RAL9010 (pure-white)



Art.-No.	ET-251xx	File	ET-251xx_NEU.indd		
Description	Frame Set for Keystone Modules				
Created	Date	Last Revision	Date	Checked	Date
Alexander Müller	23.09.2013	BT	11.02.2014	BT	11.02.2014